

DEVAR Inc.

706 BOSTWICK AVE, BRIDGEPORT, CT. 06605
TEL. (203) 368-6751 FAX. (203) 368-3747

18-SLPI-1V LOOP POWERED INDICATOR INSTRUCTION MANUAL

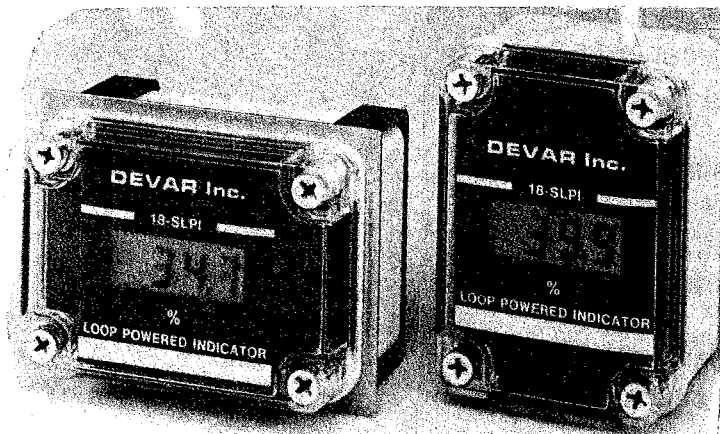

**Horizontal
Mount**

**Vertical
Mount**

TABLE OF CONTENTS**PAGE NO.****FIGURE**

General Description, 18-SLPI-1V	1-2	--
Field Wiring, 18-SLPI	2	1
Specification	3-4	--
General Dimensions for 18-SLPI-1V	4	2
Calibration Procedure	5-6	--
Lower P.C. Board with Switch Settings for Internal Calibrator	7	3
Location of Calibration Switches and Pots on the P.C. Board	7	4
Table of Calibration Switch Settings for Span, Zero, Decimal Points, and Polarity	7	5
Nema 4 Panel Mounting for 18-SLPI Option M46	8	6
Interconnecting Diagram to Intrinsically Safe Apparatus Factory Mutual Research Corporation	9	7
Canadian Standards Association	9	8

General Description

The 18-SLPI-1V is a two-wire, digital indicator, in a NEMA-4X housing, that provides local process indication on a 3-1/2 digit liquid crystal display. The Indicator features 1/2 inch high, easy to read digits and is powered directly from the 4 to 20mA input loop, dropping less than 1 volt across the input terminals.

The 18-SLPI-1V provides a digital readout directly proportional to the current input. The indicator is calibrated at the factory to read 0 to 100.0% for a 4 to 20 mA input, however, it can easily be recalibrated in the field to read directly in engineering units, such as temperature or flow. Each indicator comes with a selection of stick-on labels of commonly used engineering units such as GPM, PSI, etc. These labels can be attached to the display so that a user can immediately determine what the indicator is reading.

Recalibration of the 18-SLPI-1V is easily accomplished through the use of switches and trimpots. Information on switch positions for the various span and zero calibrations can be found printed on a label attached to the bottom side of the display's plastic label. The display span can be adjusted from 0 to 3998 counts in three switch selectable ranges and the zero offset can be adjusted from -1999 to +1999 counts also in three switch selectable ranges. Fine adjustment of span and zero is made on two 15 turn trimpots. The span and zero pots are noninteractive and provide resolutions of better than one count. Some sample display calibrations for a 4 to 20 mA input are as follows:

000 to 1999	(forward acting)
1999 to 000	(reverse acting)
-1999 to 1999	(zero center)
230 to 1735	(positive offset)
-720 to 850	(negative offset)

Negative polarity indication is available when required. The negative sign is enabled or disabled through the use of a switch and can be used when displaying quantities such as -350 to 1000 deg F. Reverse action is achieved by disabling the negative sign and applying the appropriate negative offset. Decimal point selection is also available. Three decimal point positions or no decimal point can be selected through the use of switches.

An additional feature of the 18-SPI-1V is the internal calibrator. The indicator can be field calibrated while installed in a working 4 to 20 mA loop, regardless of the current through the loop, simply by switching into the calibrate mode. The indicator can also be calibrated on the bench by using a conventional calibrator or by connecting a 1.5 volt flashlight battery across the input terminals and switching to the calibrate mode.

To gain access to the indicator assembly, remove the cover and plastic label from the housing and then grasping two opposite edges of the top P.C. Board, pull the indicator assembly out of the housing. The indicator is held in place by two banana plugs, which plug into the base board attached to the bottom of the housing. Field wiring connections are made to + and - points on terminal block located on the lower P.C. board, reference Figure 1 for field wiring. This circular assembly allows for ease of positioning within the NEMA 4X case so that the unit may be rotated 90° to provide horizontal or vertical mounting. The clear polycarbonate cover provides obstruction-free viewing of the 3-1/2 or 4-1/2 digit display.

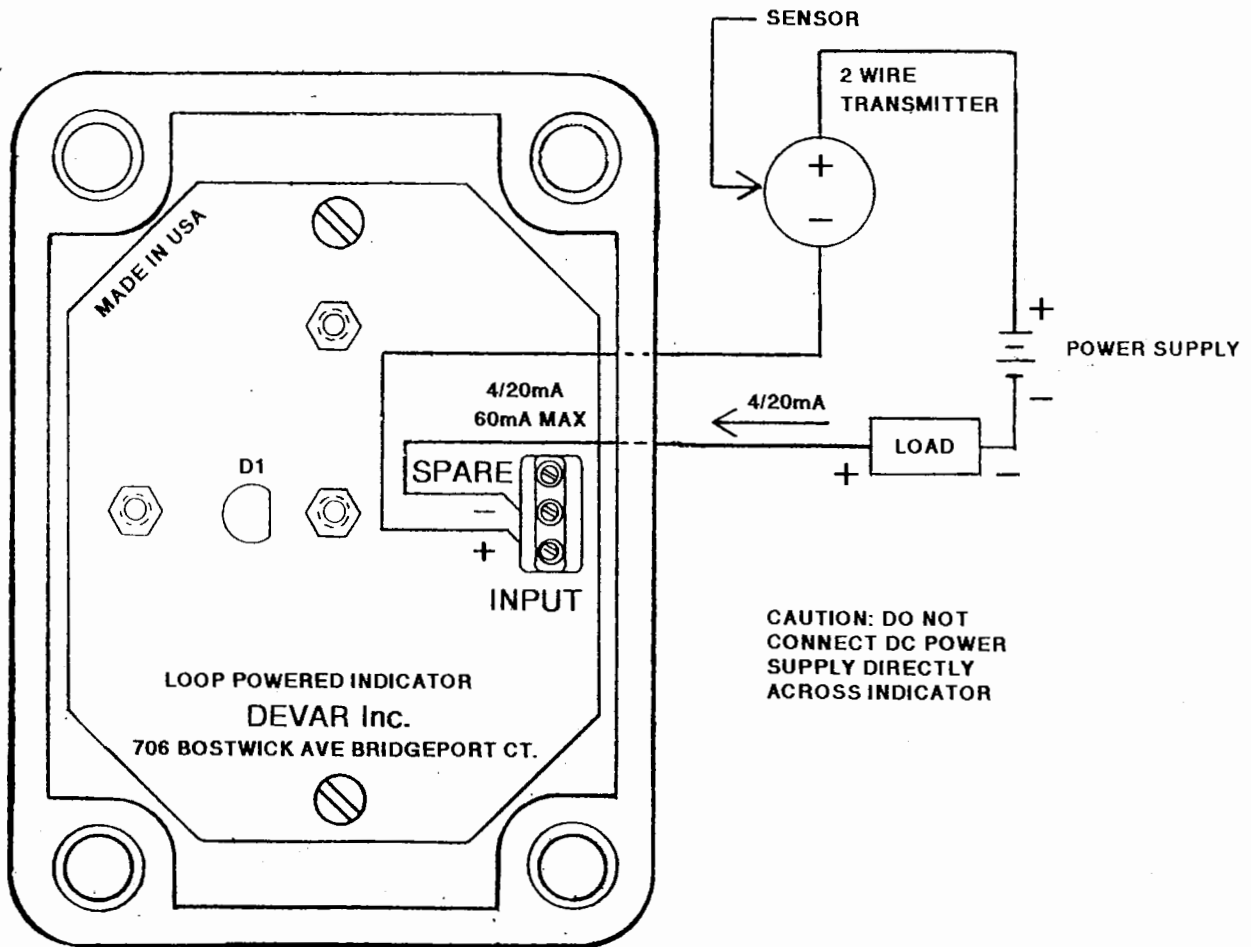

FIG. 1 - TYPICAL FIELD WIRING

Specifications

1. Input

- a. Range: 4 to 20 mA
- b. Voltage drop: .98V @ 20mA, 25 deg C
- c. Forward current overrange: 100 mA max.
- d. Reverse current: 100 mA max.

2. Display

- a. Type: 3-1/2 digit LCD, 1/2 inch high digits
- b. Range: -1999 to 1999 counts
- c. Decimal point: three positions or absent, switch selectable
- d. Polarity sign: negative polarity indication or none, switch selectable
- e. Action: forward acting (count increases with current), normal calibration; reverse acting (count decreases with current), obtained by appropriate zero setting
- f. Overage indication: display blanks except for most significant 1

3. Calibration

- a. Span range: 0 to 3998 counts, 3 ranges switch selectable, fine adjustment on 15 turn trim pot, noninteractive with zero pot
- b. Offset range: -1999 to +1999 counts, 3 range switch selectable, fine adjustment on 15 turn trim pot, noninteractive with span pot
- c. Resolution: better than 1 count

4. Performance

- a. Accuracy: +/- .1% of span counts, +/- 1 count
- b. Temperature effect (zero): +/- .1 count/deg C
- c. Temperature effect (span): +/- .01% of span counts/deg C
- d. Operating temperature: -20 to +70 deg C
- e. Ripple rejection: less than 1 count with 1 mA peak-to-peak, 60 Hz ripple at input
- f. Sample rate: 2 per second

5. Intrinsically Safe Approvals

- a. Factory Mutual Research Corporation approved for CL 1, DIV 1, GP A, B, C & D per dwg. 515107
- b. Canadian Standards Association approved for CL 1, DIV 1, GP C & D per dwg 515380

6. Housing

- a. Material: Polycarbonate housing
- b. Size: 3.15 (80) x 4.33 (110) x 2.62 (66) inches (mm).
- c. Classification: NEMA 4X housing
- d. Weight: 10.6 oz.
- e. Cover: Clear polycarbonate, keyed to fit housing only one way.

7. Options

- M31D: DIN rail mounting
- M31S: Snap track (3 inch) mounting bracket
- M36: 2 inch pipe mounting bracket
- M42: Water-tight 1/2 inch hub
- M46: NEMA 4 Panel mount hardware

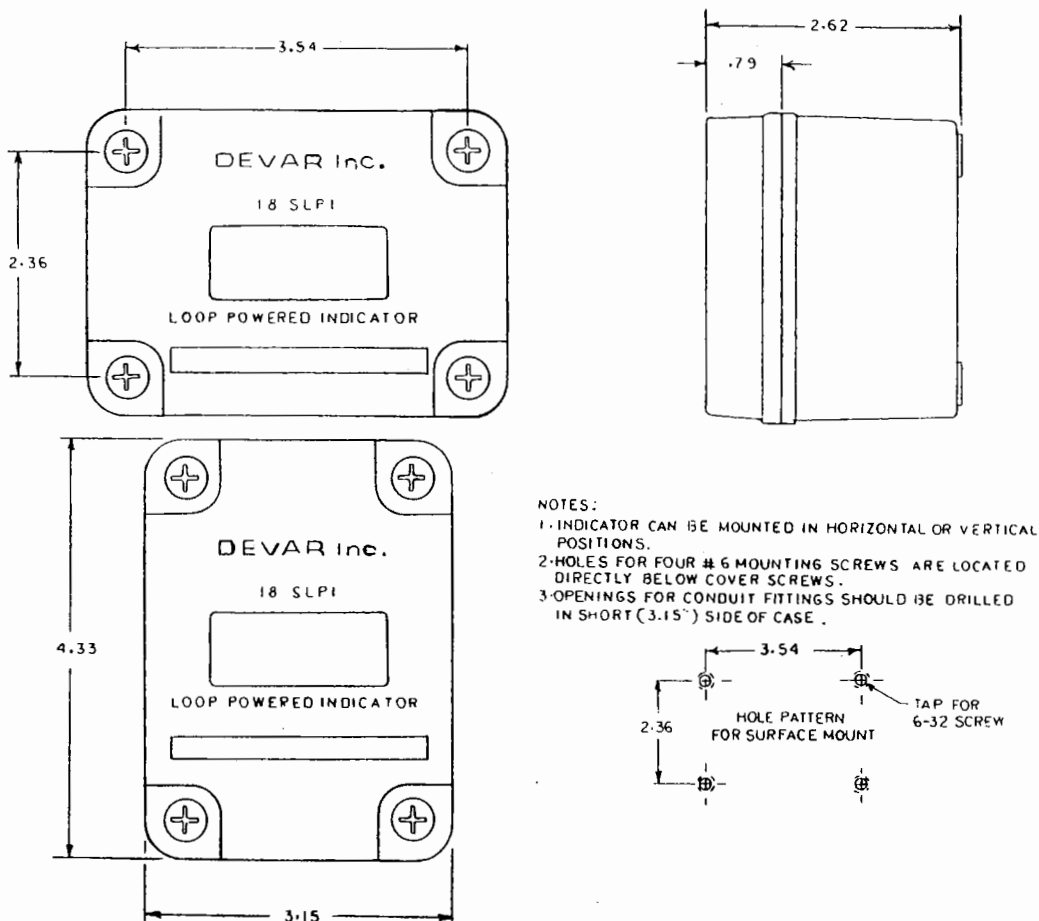

FIG. 2 GENERAL DIMENSIONS FOR 18-SLPI-1V

Calibration Procedure

1. To calibrate the 18-SLPI-1V, remove the front cover and label to expose the calibrating switches, and the span and zero pots, located on the top PC board (Figs. 3 and 4). Input a 4 to 20mA signal and calibrate the indicator as follows:
2. Set Input Voltage Drop (Factory Calibration):
Input 20 milliamps at the input terminals of the indicator. Adjust pot "P2" on the lower PC board for a voltage drop of 0.95 volts between the input terminals.
3. Zero Adjustment (Factory Calibration):
To prevent the interaction of the span and zero pots the 4 milliamp offset is compensated for at the output of amplifier "U1". To do this, input 4 milliamps into the indicator, set switch 1, position 1, on the lower PC board to the normal operating position, and then adjust pot "P1", also on the lower PC board, for 0.000 volts at the output of amplifier "U1" (measure between common and the blue wire).
4. Calibration of Internal Calibrator (Factory Calibration):
Calibrate display to read 00.0 to 100.0 for a 4 to 20 milliamp input following the instructions for the calibration of the display. With the indicator operating (the value of the input current does not matter) switch switch 1, position 1, on the lower PC board to the calibrate position. Switch switch 1, position 2 to the zero calibrate position and adjust pot "P3", on the lower PC board until the display reads 00.0. Switch switch 1, position 2 to the span calibrating position and adjust pot "P4" on the lower PC board until the display reads 100.0. Return switch 1, position 1 to the normal operating position. Note that the input current has no effect on the display while switch 1 is in the calibrate position.
5. Calibrate Display
To calibrate the 18-SLPI-1V, remove the front cover and label to expose the calibrating switches, and the span and zero pots, located on the top PC board (Fig. 4). Input a 4 to 20 mA signal and calibrate the indicator as follows:
 1. Determine desired display for a 4 to 20 mA input.
Example: -30.0 to 195.0 deg. F

2. Set span switches S1 and S2 for proper span range.
Example: $\text{Span} = 1950 - (-300) = 2250$ counts;
set S1-off, S2-off
3. Set zero switches S3 and S4 for proper zero range.
Example: Zero = -300 counts; set S3-off, S4-off
4. Select decimal point.
Example: Select P3 decimal point; set S8-on, S6-off,
S7-off
5. Enable or disable negative polarity indication.
Example: Enable negative sign; set S5-on
6. Input 4 mA and set "zero pot" for bottom of range.
Example: adjust zero pot to display -30.0
7. Input 20 mA and set "span pot" for top of range.
Example: adjust span pot to display 195.0
8. The indicator is now calibrated.

6. Use of Internal Calibrator

The 18-SLPI-1V can be calibrated using the internal calibrator, while installed in a working loop, or it can be calibrated on the bench using a 1.5 volt flash light battery connected across the input terminals as a power source.

To use the internal calibrator follow the following procedure:

1. Set the calibrating switches (FIG. 4) for the desired span and offset ranges as described in the preceding section.
2. Set switch 1, position 1 (FIG. 3) located on the lower PC board to the calibrate position.
3. Set switch 1, position 2 to the "cal. zero" position, then adjust the "zero pot" located on the top PC board until the display displays the bottom of the range.
4. Set switch 1, position 2 to the "cal. span" position, then adjust the "span pot" located on the top PC board until the display displays the top of the range.
5. Return switch 1, position 1 to the normal operate position. The indicator is now calibrated.

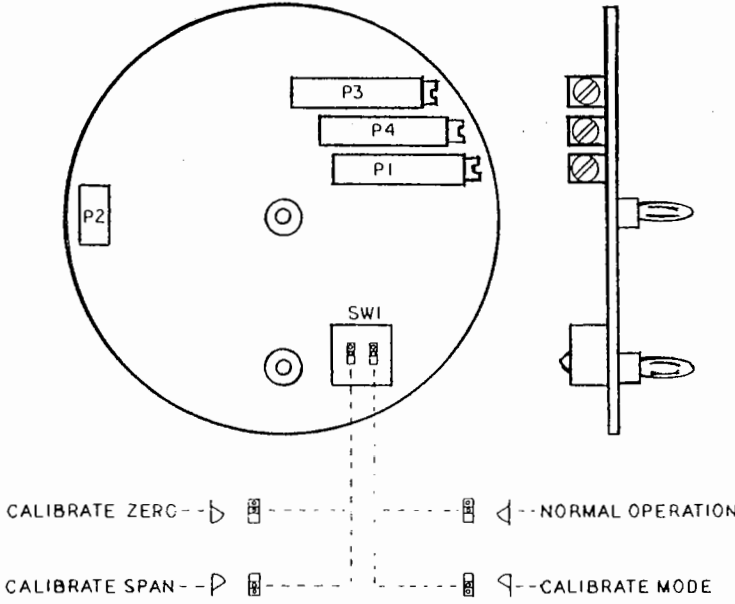

FIG. 3 LOWER PC BOARD WITH SWITCH SETTINGS FOR INTERNAL CALIBRATOR

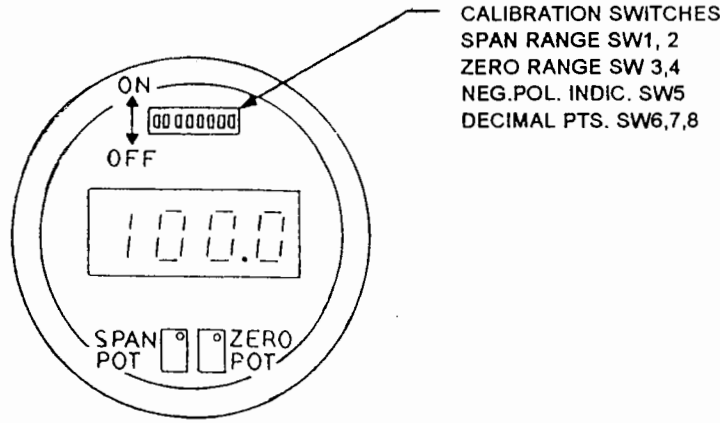

FIG. 4 LOCATION OF CALIBRATION SWITCHES AND POTS ON TOP P.C. BOARD

CALIBRATION SWITCH SETTING					
SPAN	S1	S2	ZERO	S3	S4
4000/2470	ON	OFF	2000/ 573	OFF	ON
2470/1530	OFF	OFF	573/ -573	OFF	OFF
1530/ 000	OFF	ON	-573/-2000	ON	OFF
ENABLE DECIMAL POINT			TO ENABLE NEGATIVE POLARITY INDICATION		
1.999	S6	ON	S5	ON	
19.99	S7	ON			
199.9	S8	ON			

FIG. 5 TABLE OF CALIBRATION SWITCH SETTINGS FOR SPAN, ZERO, DECIMAL POINTS, AND POLARITY

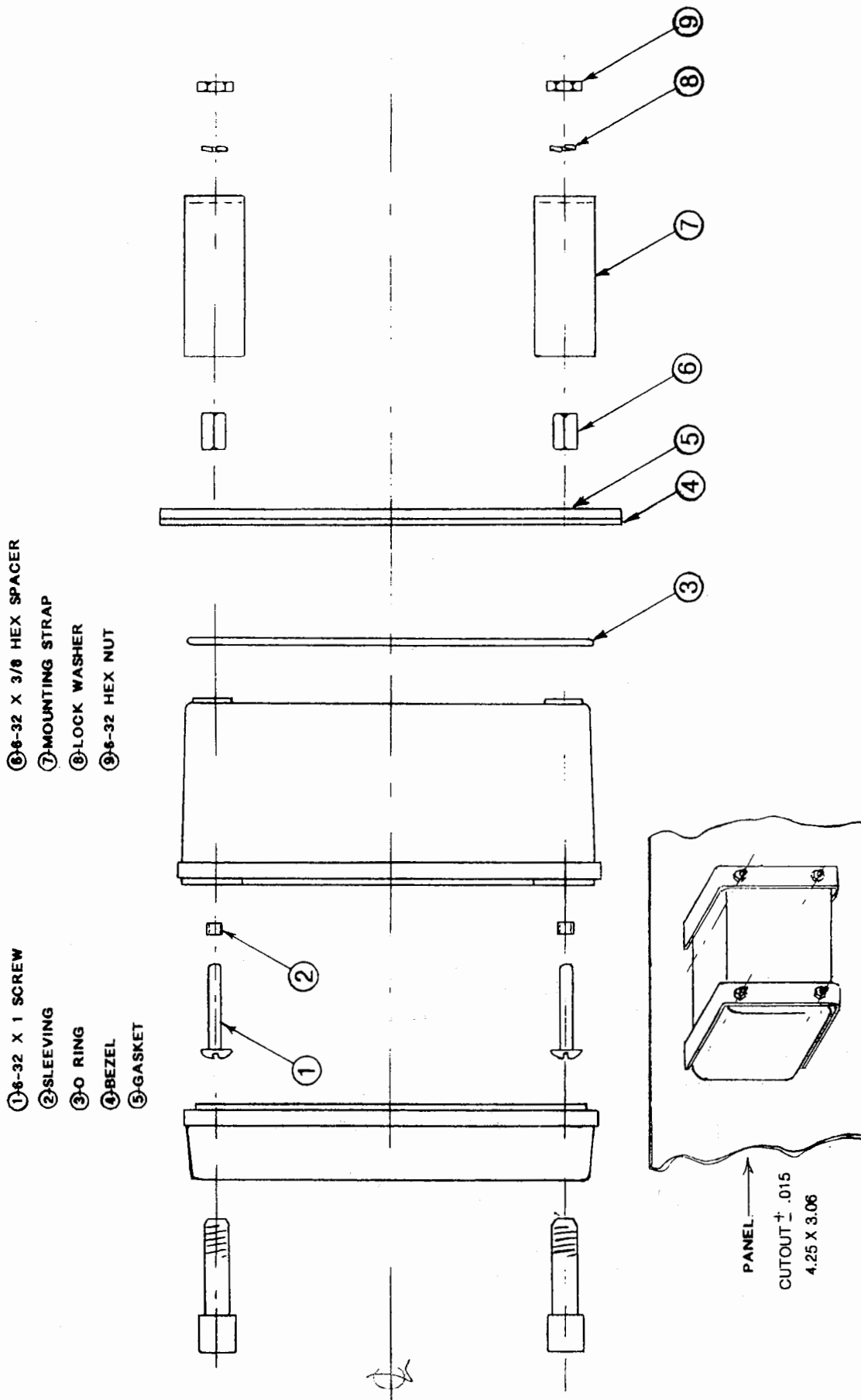
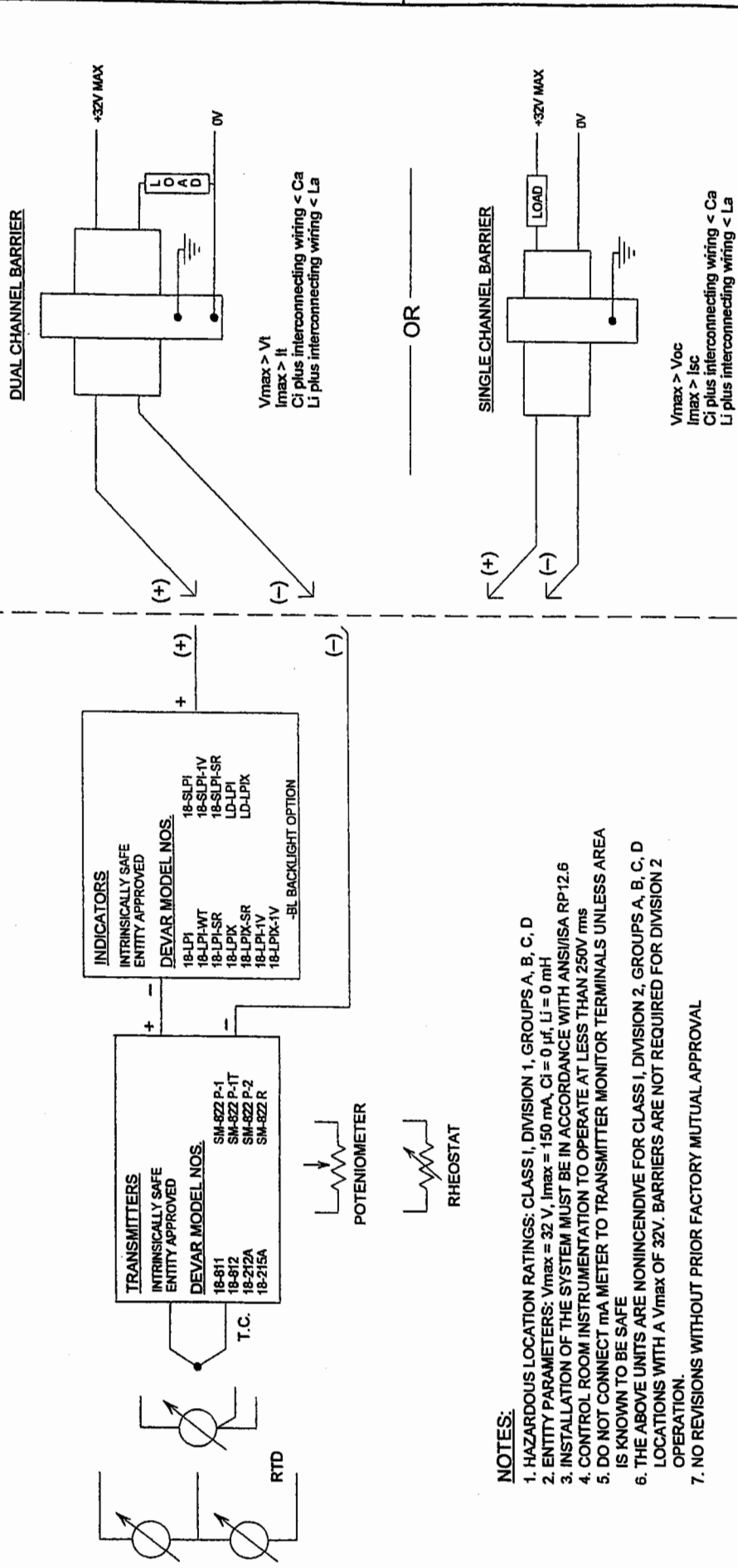

FIG. 6 NEMA 4 PANEL MOUNTING FOR 18-SLPI OPTION M46

DWG NO. 515107		SH 1	
H	ADD 18-SLPI, 18-SLPI-IV AND 18-SLPI-SR, ECN 3081A	02-08-95	AG
I	ADD LD-LPI, ECN 3154	01-22-98	AG
J	ADD SM-822P-1, SM-822P-1T, SM-822P-2 & SM-822R, ECN 3208	09-09-99	AG
K	ADD LD-LPIX & -BL BACKLIGHT OPTION, ECN 3319	7-13-05	LF
			G
			F
			E
			AG
			AG
			AG

HAZARDOUS LOCATION

NON-HAZARDOUS LOCATION



NOTES:

- HAZARDOUS LOCATION RATINGS: CLASS I, DIVISION 1, GROUPS A, B, C, D
- ENTITY PARAMETERS: $V_{max} = 32V$, $I_{max} = 150mA$, $C_i = 0\mu f$, $L_i = 0mH$
- INSTALLATION OF THE SYSTEM MUST BE IN ACCORDANCE WITH ANSI/ISA RP12.6
- CONTROL ROOM INSTRUMENTATION TO OPERATE AT LESS THAN 250V rms
- DO NOT CONNECT mA METER TO TRANSMITTER MONITOR TERMINALS UNLESS AREA IS KNOWN TO BE SAFE
- THE ABOVE UNITS ARE NONINCENDIVE FOR CLASS I, DIVISION 2, GROUPS A, B, C, D LOCATIONS WITH A V_{max} OF 32V. BARRIERS ARE NOT REQUIRED FOR DIVISION 2 OPERATION.
- NO REVISIONS WITHOUT PRIOR FACTORY MUTUAL APPROVAL

DEVAR Inc. 705 Bostwick Avenue, Bridgeport, Conn. 06605 TEL: (203) 368-6751 FAX: (203) 368-3747	
INTERCONNECTING DIAGRAM TO INTRINSICALLY SAFE APPARATUS	
CONTRACT NO.	08-16-05
PREPARED	RNT
DRAWN	LF
CHECKED	7-13-05
MECH	
ELEC	
DESIGN	
APPROVED	
APPROVED	
UNSPECIFIED DIMENSION TOLERANCE	
FRACTION	±.010
DECIMAL	±.005
ANGLE	±.10 DEGREE
MATERIAL	-N/A-
FINISH	-N/A-
NEAT ASSEMBLY NO.	NONE
SIZE	B
DRAWING NO.	515107
SCALE	NONE
REV	K
SHEET	1 OF 1

